

DESCRIPTION
 HP75/HP100 (O-ring Design) CLOSE COUPLED MOTOR PUMP ASSY (METRIC)

REF. NO.
 M-HP75-100

DATE
 5/18/11

REV.
 A

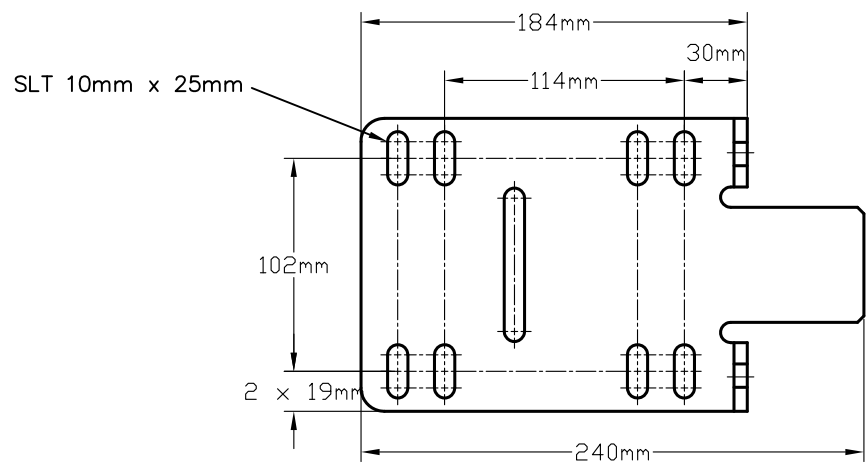
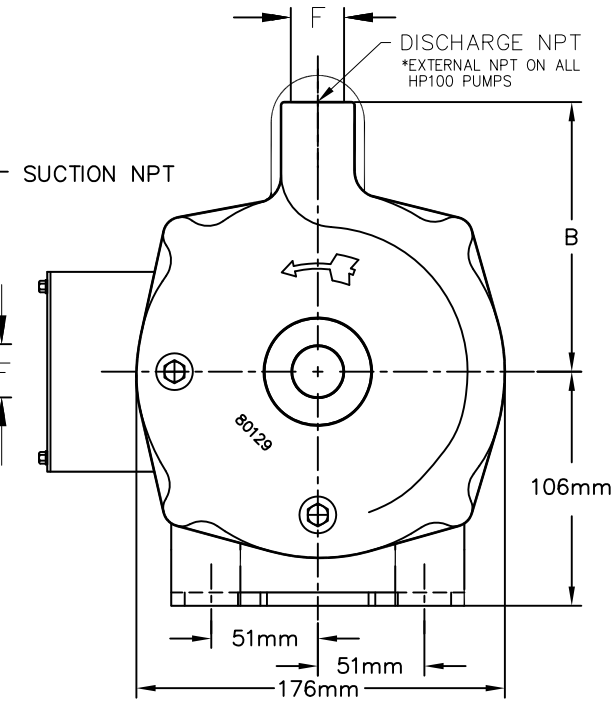
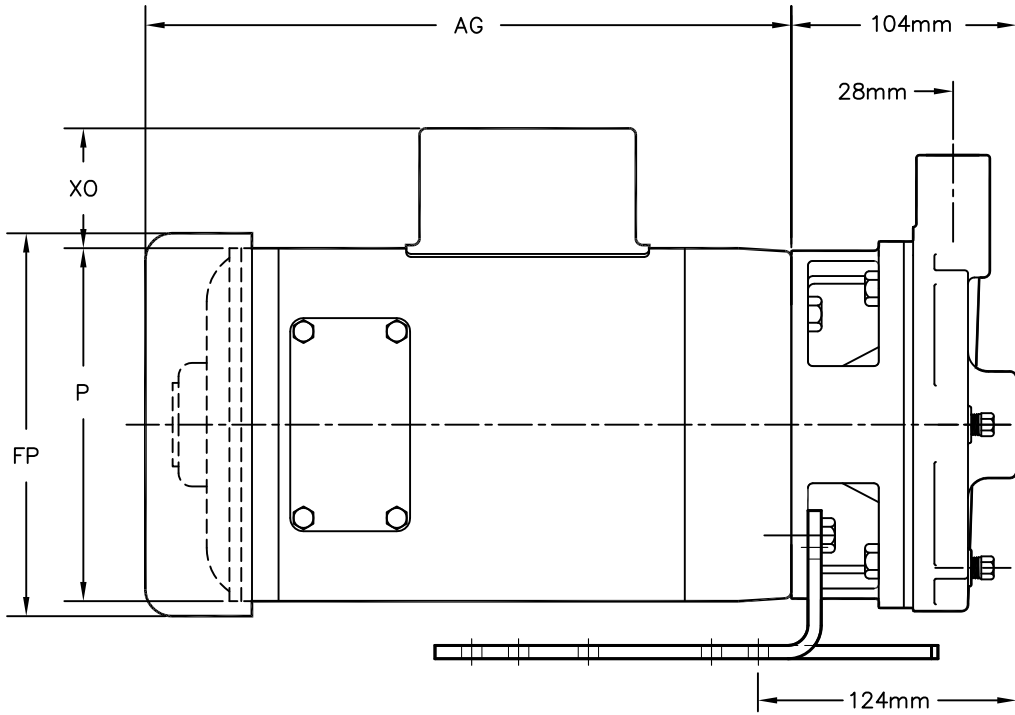

MATERIAL	MODEL	B	F
SS	HP75SS/HP75SC	129	19
BRONZE	HP75AB	129	19
SS	HP100SS/HP100SC	127	25
BRONZE	HP100AB	127	25

HP	RPM	FRM	MOTOR END DIMENSIONS			
			AG	FP	O	XO
1/3	3600	56J	216	156	137	52
1/2	3600	56J	222	156	137	52
3/4	3600	56J	235	183	175	52
1	3600	56J	248	183	175	52
1 1/2	3600	56J	267	183	175	52
2	3600	56J	275	183	175	52
3	3600	56J	281	183	175	N/A
*5	3600	56J	283	N/A	175	N/A

NOTES UNLESS OTHERWISE SPECIFIED:
 ALL DIMENSIONS ARE GIVEN IN MILLIMETERS, ± 2mm.

NOTE:

MOTOR DIMENSIONS WILL VARY BY MODEL AND MAKE,
 DIMENSIONS ARE TO BE USED FOR REFERENCE ONLY.
 * 3 PHASE OPEN DRIP PROOF ONLY.

9930122.1103

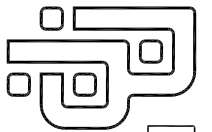

PRICE PUMP CO.

FACTORY FAX TRANSMITTAL DRAWING

21775 Eighth Street East
 Sonoma, CA 95476 (707) 938-8441
 707-FAX 938-0764