



XL/XT Parts List

PRICE PUMP CO.

XT_XLplist.doc rev. F

Key #	Description	Qty.	Part Numbers				
A.	Volute		<u>Al Thd.</u>	<u>BF Thd.</u>	<u>AB Thd.</u>	<u>SS Thd.</u>	<u>SS Flanged</u>
	1 x 1-1/2 - 6 (XT100 Threaded, XL100 Flanged)	1	2601	2601	2603	2629	2605
	1-1/2 x 2 - 6 (XT150 Threaded)	1	2607	2607	2609	2626	-
	1-1/2 x 3 - 6 (XL150 Flanged)	1	-	-	-	-	2611
	2 x 3 - 6 (XT200 Threaded, XL200 Flanged)	1	2613	2613	2615	2627	2617
B.	Impeller - specify diameter **						
	1 x 1-1/2 - 6 (XT100 Threaded, XL100 Flanged)	1	2602-dia	2604-dia	2604-dia	2606-dia	2606-dia
	1-1/2 x 2 - 6 (XT150 Threaded)	1	2608-dia	2610-dia	2610-dia	2612-dia	
	1-1/2 x 3 - 6 (XL150 Flanged)	1					2612-dia
	2 x 3 - 6 (XT200 Threaded, XL200 Flanged)	1	2614-dia	2616-dia	2616-dia	2618-dia	2618-dia
	Note: For Dbl seal add DS (Sample: 2614 DS -dia)						
C.	Bracket (standard)	1	0131	0131	2637	0979	0979
	Double Seal		0131-1	0131-1	2637-1	0979-1	0979-1
	Single Flush		0131-2	0131-2	2637-2	0979-2	0979-2
	Quench		0131-3	0131-3	2637-3	0979-3	0979-3
	Internal Flush		0131-4	0131-4	2637-4	0979-4	0979-4
	Bracket for 213/215 JM	1	3405	3405	3388	3388	3388
	O-ring		3405-0	3405-0	N/A	N/A	N/A
	Double Seal		3405-1	3405-1	N/A	3388-1	3388-1
	Single Flush		3405-2	3405-2	N/A	3388-2	3388-2
	Flush w/ Quench		3405-5	3405-5	N/A	3388-5	3388-5
D ¹ .	Shaft Sleeve (for std. JM motor)	1	0127	0127	0127	0127	0127
D ² .	Stub Shaft 5/8" ID (56C) optional	1	0329-1	0329-1	0329-1	0329-1	0329-1
D ³ .	Stub Shaft 7/8" ID (143TC/145TC/182C/184C)	1	0328-1	0328-1	0328-1	0328-1	0328-1
E.	Volute Gasket (Synthetic Fiber, std.)	1	0124	0124	0124	0301 (PTFE)	0301 (PTFE)
F.	Pipe Plug *(2 rqd Threaded, 1 rqd Flanged)	*	0557	0557	0558	0559	0559
G.	Volute Bolts	8	0583	0583	0587	0724	0724
H ¹ .	T.21 Single Seal/Seat	1	0121 (std B*)	0121 (std B*)	0121 (std B*)	0122 (std V*)	0122 (std V*)
	B* = Buna						
	V* = Fluorocarbon						
	T.2 Single Seal/Seat (opt)	1	3920	3920	3920	3920	3920

All Models

Key #	Description	Qty.	Part Numbers
H ² .	T.9 PTFE Single Seal/Seat (opt)	1	0123
	Seat Pin T.9 (not shown)	1	0890
H ³ .	T.21 Double Seal/Seat (opt)	1	Specify P/N
	Double Seal Plate	2	0309
	Plate Gasket, PTFE	2	0505
	Plate Bolts	6	0977
H ⁴ .	Seal Quench (opt):		
	Buna Lip Seal	1	0756
	Fluorocarbon Lip Seal	1	0757
	PTFE Lip Seal	1	0758
	Lip Seal Plate	1	0309-2
	Plate Gasket, PTFE	1	0505
	Plate Bolts	3	0977
H ⁵ .	T.9 PTFE Double Seal/Seat (opt)	1	0670
	Double Seal Plate	2	0309-1
	Plate Gasket, PTFE	2	0505
	Plate Bolts	6	0977
	Seat Pin T.9 (not shown)	2	0890
J.	Impeller Lockdown	1	0978
K.	Lockdown Gasket, PTFE	1	0245



XL/XT Parts List

PRICE PUMP CO.

XT_XLplist.doc rev. F

All Models

Key #	Description	Qty.	Part Numbers
L.	Motor Bolts		
	All Bronze pumps		0592
	Stainless Steel pumps	4	0593
	AI & BF pump	4	0593
	AI & BF pump Washers	4	1137
	Motor Bolts for 3405 & 3388 brackets		
	All Bronze pumps		N/A
	Stainless Steel pumps	4	1189
	AI & BF pumps	4	1189
	AI & BF pumps Washers	4	1199
	Motor Bolts for 5/8" & 7/8" Shaft Units		
	All pumps – all pumps require both		
	Top motor bolts	2	60-029-00
	Bottom motor bolts	2	60-024-00
	AI & BF need washers	4	1137
M.	Sleeve Gasket, PTFE	1	0245
N.	Impeller Shaft Key	1	0135
P1.	JM Motor	1	Specify P/N
P2.	'C' Face Motor (not shown)	1	Specify P/N
P3.	Air Motor	1	Specify P/N
P4.	Power Frame	1	5480
Q.	12 Volt Clutch (opt)	1	1983
	Key for Clutch	2	0136
	Lock bolt for Clutch	1	0567
	Lock bolt Washer for Clutch	1	0564
R.	Ext. Plate for 5/8" & 7/8" Shafts	1	3690
S.	Base	1	0197



PRICE® PUMP CO.

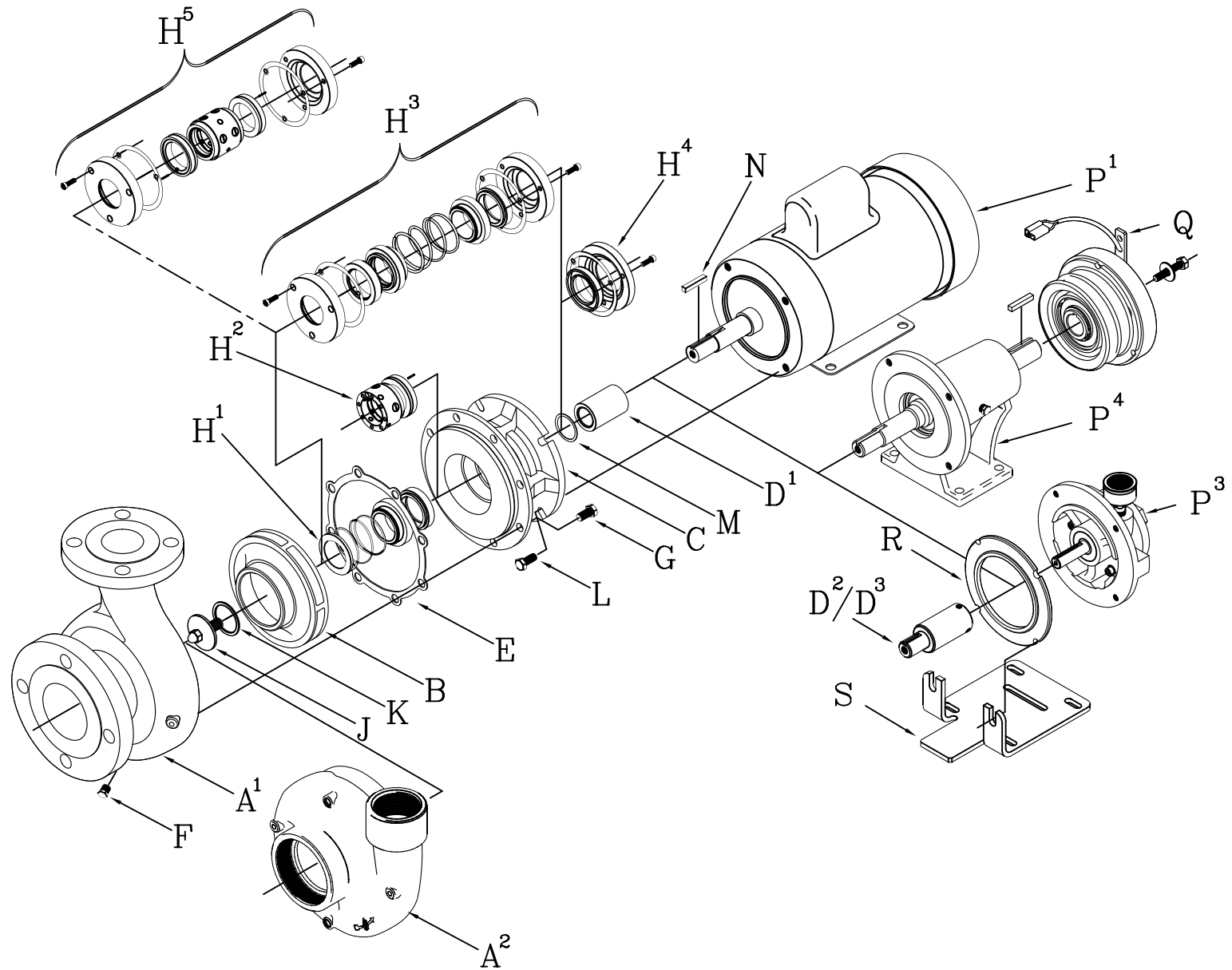

Price® Pump Co.

2203 Smeed Parkway * Caldwell, ID 83605 * (208) 402-6871 * Fax (208) 402-6856