



Price® Pump Co.

INSTALLATION, OPERATING AND MAINTENANCE MANUAL

TYPE CD VERTICAL CENTRIFUGAL PUMPS

MODELS: CD - 100V, 150V

PLEASE FILL IN FROM PUMP NAMEPLATE

Pump Model _____

BOM. No. _____

Serial No. _____

Price® Pump Company
2203 Smeed Parkway
Caldwell, ID 83605
Tel: 208-402-6871
Fax 208-402-6856
Email: sales@pricepump.com

RETAIN MANUAL FOR REFERENCE

Congratulations

You are now the owner of a Price® Pump Co. Centrifugal Pump. This pump was carefully inspected and subjected to final performance tests before being released for shipment. In order to achieve maximum performance and reliability, please follow the simple instructions in this manual.

RECOMMENDED PRECAUTIONS

1. For satisfactory operation and safety, maximum system pressure must not exceed 350 psi* (24.6kg/sq cm).
2. For satisfactory operation and safety, maximum fluid temperature must not exceed 300°F* (121°C).
3. No modifications, additions or deletions should be made to the pump without prior approval of the factory.
4. Drain pump completely and flush with water before servicing a pump handling volatile or harmful liquids.

READ CAREFULLY THE CAUTION BELOW

The performance of your Price® Pump Co. Centrifugal Pump is based on clean, room temperature, water with suction conditions as shown on the performance curves. If used to pump liquids other than water, pump performance may differ from rated performance based on the different specific gravity, temperature, viscosity, etc. of the liquid being pumped. A standard pump, however, may not be safe for pumping all types of liquids, such as toxic, volatile or chemical liquids, or liquids under extreme temperatures or pressures.

Please consult Price® Pump Co. technical specifications as well as local codes and general references to determine the appropriate pump for your particular application. Since it is impossible for us to anticipate every application of a Price® Centrifugal pump, if you plan to use the pump for a non-water application, contact Price® Pump Co. beforehand to determine whether such application may be appropriate and safe under the operating conditions. Failure to do so could result in property damage or personal harm.

* Depends on seal materials and seal type

Visit our website for product information and technical support

www.pricepump.com

INSTALLATION / OPERATING INSTRUCTIONS

Warning

Before installing, repairing or performing maintenance on this pump, read these instructions completely.

Disconnect power to pump before servicing to avoid dangerous or fatal electrical shock.

Match supply voltage and frequency to motor nameplate values. Incorrect voltage can cause fire or serious motor damage and void warranty.

Ground motor before connection to electrical power supply! Failure to ground motor can cause severe or fatal electrical shock!

Do not ground to gas supply line!

Before disassembling pump, be certain all liquid has been removed. If pump was used to pump hazardous or toxic fluid, it must be decontaminated prior to disassembly.

Close Coupled Motor Pumps

It is suggested that these pumps be firmly bolted to a level surface. Adequate air movement around motor will help prevent overheating.

Do not over tighten inlet and outlet piping or volute may be damaged.

Power Frame Mounted Pumps

Power Frame mounted pumps must be mounted on a rigid base that will not warp or flex. Each pump must be mounted such that the pump shaft centerline is in-line with the driver shaft centerline. Pads and/or shims will be required on the pump, the driver or both to insure proper alignment. The two shafts should not touch each other (end to end) and the distance between them depends on the coupling used to connect them.

Misalignment will cause vibration, bearing failure and void warranty. Pumps are rough aligned at the factory

but must be realigned after shipment and installation.

Pulley driven pump must have pulleys inline and proper belt tightness practices followed.

Direction of Rotation

Note: Motor shaft rotation is viewed from the suction end of pump. A rotational arrow is shown on the front of the pump volute casing. Incorrect rotation can cause pump damage, failure or reduced performance, voiding warranty. It is best to check rotation by momentarily energizing or jogging the motor prior to filling pump with liquid.

Warning! Do not operate pump without liquid as damage may result to the pump internal wear surfaces.

Plumbing

All piping needs to be supported independently of the pump. Piping connections should not exert any stress on the pump volute or fittings.

INSTALLATION / OPERATING INSTRUCTIONS

Suction Piping (Inlet)

(Horizontal Pumps)

Suction line must provide adequate suction pressure and even (Laminar) liquid flow for proper pump operation. Air, entrapped in the suction line due to leaks or improper piping design, may cause the pump to lose prime. Non-priming pumps must have their suction 'flooded' at start up (see datasheets for minimum NPSHR). Also, the suction line must provide sufficient pressure (NPSH) and even flow to pump inlet to prevent pump cavitation. The suction pipe entering the pump should be straight and a minimum length of 5 times and preferably 10 times the pump inlet diameter. Elbows, fittings or valves installed close to the pump inlet can disrupt liquid flow and cause cavitation. Suction lines must be at least the same diameter as the pump inlet or larger if possible.

Price Pump Company recommends against using foot valves in the suction line to maintain liquid in the pump when it's not operating. If foot valves are used, due to suction lift conditions, they must be properly maintained to avoid

leaks resulting from wear or fouling. Suction piping must be designed to prevent vapor from being trapped in high spots in the piping. This condition may cause the pump to vapor lock.

Discharge Piping (Outlet)

To control flow and discharge head, it is advisable to install a valve (globe, ball, or other adjustable and non-leak type) in the discharge line adjacent to the pump. The valve may be closed during system repairs to prevent backflow. By installing a check valve in the discharge line, backflow can also be prevented during maintenance or during periods of pump stoppage.

Operation

All centrifugal pumps must be filled with liquid prior to start up. It is suggested that during initial start up the discharge valve be closed and then opened as the motor reaches full rpm's. If pump does not build up pressure as motor speed increases, shut down and make sure that liquid flow into pump is not restricted (see "Troubleshooting").

Note: A centrifugal pumps flow rate and head (pressure) will vary with the amount of resistance (pipe friction and flow restrictions) in the discharge line. As the valve on the discharge line opens, the flow rate and motor amperes draw will increase and head (pressure) will decrease. As the valve on the discharge line is closed, the flow rate and amperes draw will decrease and the head (pressure) will increase.

If resistance in the discharge line is not sufficient, the pump will operate at a condition of maximum flow, sometimes called "end of curve" performance. Maximum horse-power is required to operate at this point and motor overload may result. If excessive amperes draw and motor overload is occurring, reduce the system flow rate by installing a valve or orifice in the discharge line to control (restrict) the pumps flow rate. Alternatively, reduce pump head by trimming impeller to a smaller diameter.

Consult Price Pump or a local Price Pump distributor for assistance.

www.appsupport@pricepump.com

TROUBLESHOOTING

1. Pump fails to build head pressure:

Check for:

- a. Pump not primed.
- b. Incorrect pump rotation.
- c. Driver speed too low.
- d. Suction line restricted.
- e. Driver failure.
- f. Plugged or damaged impeller.
- g. Pump or impeller undersized.
- h. Pump cavitation.
- i. Improper impeller clearance.

2. Pump fails to provide enough flow rate.

Check for:

- a. System resistance too high.
- b. Pump undersized.
- c. Pump not primed.
- d. Driver speed too low.
- e. Poor suction conditions.
- f. Improper impeller clearance.

3. Excessive noise or vibration during operation.

Check for:

- a. Motor bearing failing.
- b. Pump cavitation.
- c. Improper impeller clearance.

4. Leaking mechanical seal.

Check for:

- a. Improper assembly.
- b. Worn or cracked seal faces.
- c. Abrasive material in fluid.
- d. Liquid flashing at seal faces (Fluid temperature too high).
- e. Seal pressure rating too low for the service.
- f. Chemical attack of seal components.
- g. Seal operated dry or with a liquid having poor lubricating properties.

5. Pump gradually loses pressure and head.

Check for:

- a. Increasing temperature causing cavitation or liquid vaporization.
- b. Driver failure.
- c. Suction lift too high.
- d. Air entering suction line.

6. Motor overheating.

Check for:

- a. Excessive flow and amp draw (Throttle discharge).
- b. Low voltage or frequency.
- c. Flow rate too low with resulting heat rise.
- d. Bearing failure.
- e. System temperature too high.

REPAIR AND MAINTENANCE

Before attempting any repairs under warranty, contact Price Pump to obtain factory authorization. Repairs carried out without authorization may void warranty. Many causes of pump failure are due to improper system design. Refer to the trouble shooting list in this manual before carrying out pump inspection or repair.

Disassembly

1. Disconnect power supply to motor.
2. Disconnect electrical connections tagging wires carefully to preserve correct rotation.
3. Remove pump and motor assembly to repair area. Observe position of all parts prior to disassembly.
4. Unscrew volute bolts and remove volute from pump.
5. Remove impeller. Unscrew impeller lockdown. Slide impeller off shaft. Do Not Throw shaft key away.
6. Remove motor bolts and remove column from motor.
7. Loosen setscrews in pump shaft and remove pump shaft from motor shaft.

Note: New setscrews are recommended when pump shaft is reinstalled.

Reassembly

1. Clean pump and motor shaft thoroughly.
2. Assure that the shaft is not grooved and that there is no evidence of pitting or fretting where the bushing rides.

If the shaft is grooved, fretted or worn, replace it.

3. Install the pump shaft onto the motor shaft. Align two half-dog setscrews with keyway in motor shaft.
4. Install bushing and plate into column. Tighten three hex cap screws securely

Note: Non-galling thread compound must be used on the hex cap bolts.

5. Install column onto motor being careful not to damage bushing.
6. Install motor bolts and tighten.
7. Insure shoulder of shaft is protruding above bushing before installing impeller. Slide impeller onto pump shaft, install shaft key and tighten impeller lockdown securely.
8. Install new volute gasket / O ring and mount volute. Secure with bolts and tighten evenly.
9. Set impeller clearance. Slide pump shaft towards volute until impeller touches volute. Back the

impeller and shaft away from the volute approximately .020" and tighten one setscrew at this time.

10. Invert pump and rotate pump shaft by hand to ensure impeller does not rub against volute.

11. Remove volute, impeller, and column.

12. Tighten the half-dog setscrew in keyway securely.

13. Dial indicating "Total Indicated Run-Out". Using a magnetic base and dial indicator align shaft with maximum TIR of .004" (Note: dial indicator should be set to run as close to end of shaft as possible). The three setscrews at the base of the pump shaft are used to align the shaft. Tighten the three setscrews evenly until TIR of .004" is accomplished. Note: when TIR is completed all the setscrews must be tight.

14. Install column onto motor being careful not to damage bushing.

REPAIR AND MAINTENANCE

16. Install impeller. Slide impeller onto shaft and install impeller washer and lockdown (note: Loctite must be used on the lockdown bolt). Tighten evenly.
17. Install new volute O-ring and mount volute. Secure with bolts and tighten evenly.
18. Invert pump and rotate pump shaft by hand to ensure impeller does not rub against volute.
19. Return pump to installation, reconnect electric connections.
20. Start pump momentarily to observe shaft rotation. If rotation corresponds to the rotation arrow, pump may be put into service. If rotation is incorrect, switch any two leads on 3-phase motors. Check wiring diagram of motor for single-phase rotation.
21. Start pump allowing adequate time to purge all air from system. Observe any gauges, flow meters, etc. to see if pump performs properly.

Checking pump shaft run-out: Place the motor with the shaft facing up. Attach a dial indicator with a magnetic base or clamp with a plate bolted to the motor (as shown). Place the dial indicator on the end of the shaft and rotate the shaft. The Total Indicated Run out (TIR) should be no greater than .004".

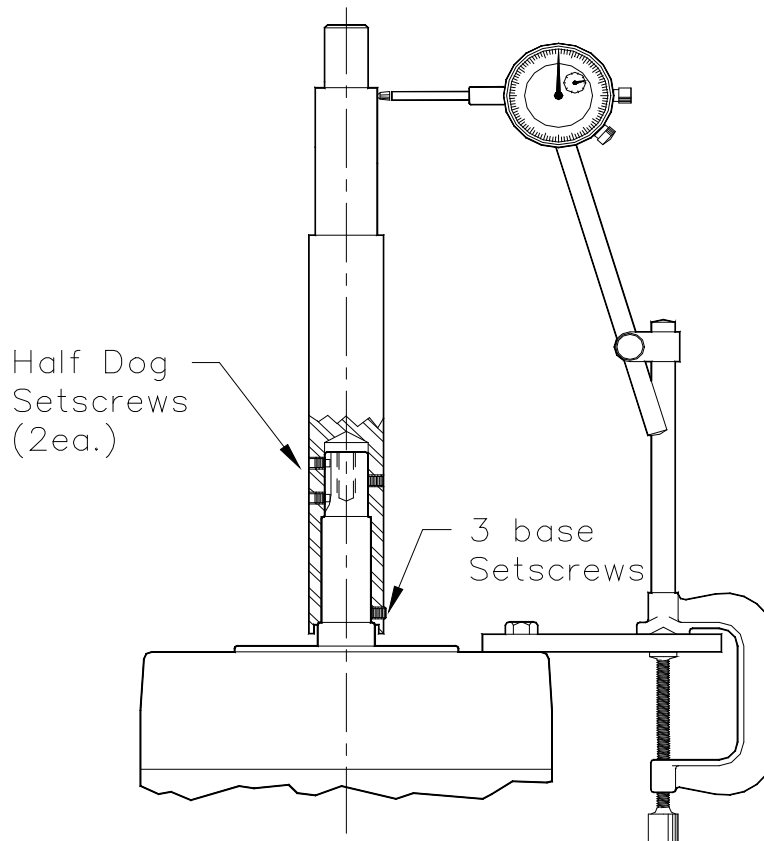



CD V 100/150 Parts List

PRICE® PUMP CO.

CDV_plist.doc Rev. C

Key #	Description	Quantity	AI	BF	SS
A.	Volute				
	CD100V	1	2401	2401	0247
	CD150V	1	2407-0	2407-0	2411-0
B.	Impeller				
	CD100V	1	2402V-dia	2404V-dia	2448V-dia
	CD150V	1	2408V-dia	2410V-dia	2412V-dia
C.	5/8" Shaft w/Setscrews				
	6 1/2" SS	1	N/A	N/A	2430-1
	13" SS	1	2431-1	2431-1	2431-1
	20" SS	1	2432-1	2432-1	2432-1
	32" SS	1	2433-1	2433-1	2433-1
	44" SS	1	2434-1	2434-1	2434-1
	7/8" Shaft w/Setscrews				
	6 1/2" SS	1	N/A	N/A	2435-1
	13" SS	1	2436-1	2436-1	2436-1
	20" SS	1	2437-1	2437-1	2437-1
	32" SS	1	2438-1	2438-1	2438-1
	44" SS	1	2439-1	2439-1	2439-1
	Shafts Include:				
	Half Dog Setscrews	1	0566	0566	0566
	Cup Point Setscrews	3	0680	0680	3080
D.	Bushing:				
	Composite #1	1	0791	0791	
	Composite #2	1	0793	0793	
	Carbon Graphite (std)	1	0676	0676	0676
	Glass Filled PTFE (opt)	1	1135	1135	1135
	Silicon Carbide (opt)	1	0616	0616	0616
	Pin for GFT & Sil/Carbide	1	0890	0890	0890
E.	Bushing Plate	1	0747	0747	0747
	Bushing Plate for Sil/Carbide	1	0747ASC	0747ASC	0747ASC
F.	Bushing Plate Screws	3	0256-038	0256-038	0256-038
G ¹ .	O-Rings (only for CD150V)				
	Fluorocarbon (std.)	1	3070	3070	3070
	Neoprene	1	3072	3072	3072
	Buna	1	3074	3074	3074
	PTFE (Teflon)	1	3071	3071	3071
	EPR	1	3073	3073	3073
G ² .	Gasket, CD100V only				
	Syn Fiber	1	0506	0506	N/A
	PTFE	1	N/A	N/A	0507
H ¹ .	Column Assembly				
	13" CI	1	0395-5	0395-5	N/A
	20" CS	1	3373-20	3373-20	N/A
	32" CS	1	3373-32	3373-32	N/A
	44" CS	1	3373-44	3373-44	N/A
H ² .	Column Assembly				
	6 1/2" SS	1	N/A	N/A	0468
	13" SS	1	N/A	N/A	0467

Price® Pump Co.

2203 Smeed Pkwy * Caldwell, ID 83605 * (208) 402-6871 * Fax (208) 402-6856

IN165_CD Vertical Rev. D



CD V 100/150 Parts List

PRICE® PUMP CO.

CDV_plist.doc Rev. C

Key #	Description	Quantity	AI	BF	SS
	20" SS	1	N/A	N/A	0466
	32" SS	1	N/A	N/A	0472
	44" SS	1	N/A	N/A	0469
I.	Volute Bolts	8	0376	0376	0917
J.	Motor Bolts	4	0592	0592	0592
K.	1/8" Pipe Plugs	2	0559	0559	0559
L.	Fume Barrier (opt)				
	Fluorocarbon – for 5/8" shaft	1	0875	0875	0875
	Fluorocarbon – for 7/8" shaft	1	0877	0877	0877
	PTFE (Teflon) – for 5/8" shaft	1	0876	0876	0876
	PTFE (Teflon) – for 7/8" shaft	1	0878	0878	0878
M ¹ .	Plate Assy (opt, used w/ H ¹)				
	12" x12" Steel (for 13" CI)	1	0903	0903	N/A
	12" x12" Steel (for 20"-44" CS)	1	0903-1	0903-1	N/A
M ² .	Plate Assy (opt, used w/ H ²)				
	12" x 12" Stainless Steel	1	N/A	N/A	0904
N.	Motor, (electric or air)	1	Specify Part Number		
P.	Impeller Lockdown Bolt	1	0575	0575	0575
R.	Impeller Flat Washer	1	2423	2423	2423
S.	Impeller Flat Lockdown Key	1	2424	2424	2424
T.	Impeller Flat lock Washer	2	2344	2344	2344



PRICE PUMP CO.

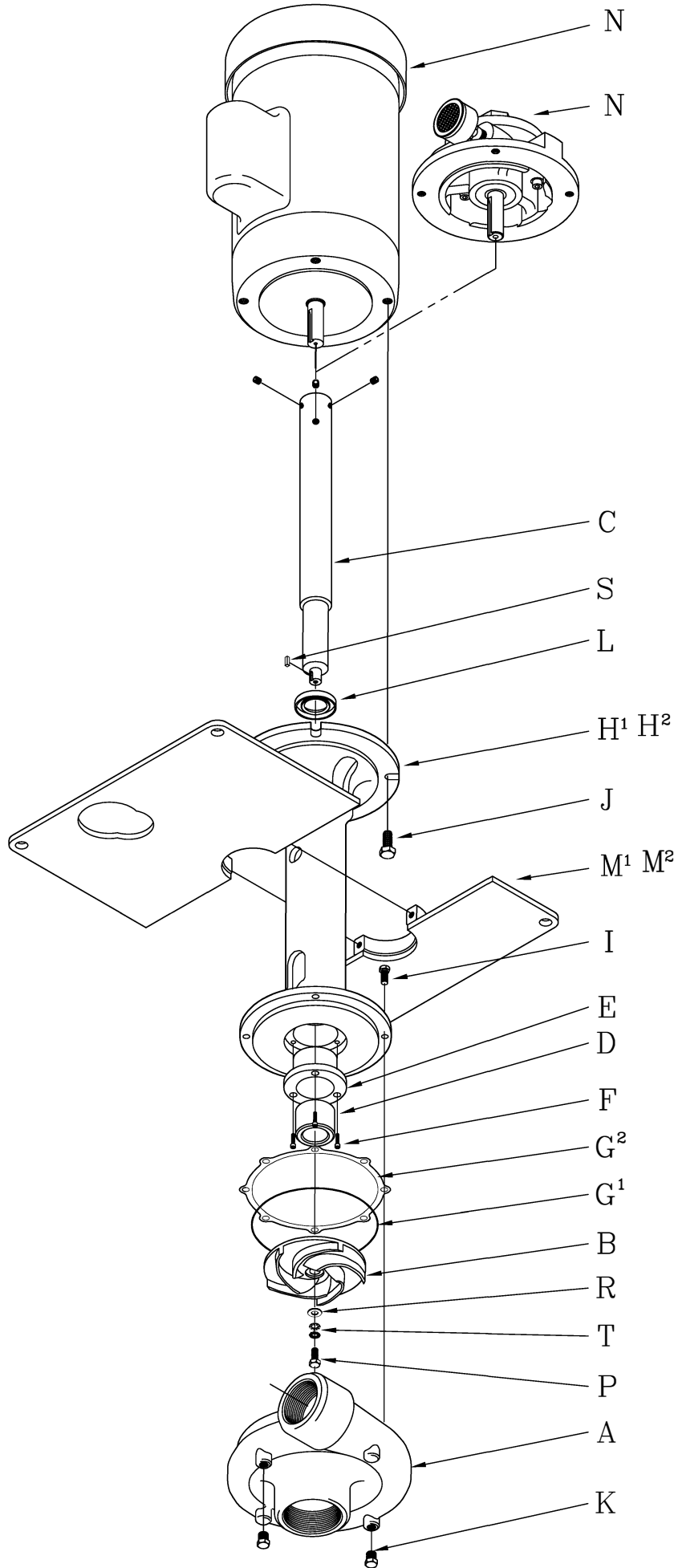

CD100/150 VERTICAL

PRICE CENTRIFUGAL PUMP CAUTIONS & WARNINGS

- **CAUTION:** Price Pump centrifugal pumps must be operated above minimum flow rate to avoid damage.
- **CAUTION:** All Price Pump centrifugal pumps require the suction to be flooded.
- **CAUTION:** It is recommended that all piping connections to the pump be flexible.
- **WARNING:** Verify chemical compatibility of the pump materials of construction with the fluid being pumped.
- **WARNING:** Price centrifugal pumps are not designed for use in sanitary or food applications.
- **CAUTION:** Use only Price Pump original equipment factory replacement parts.
- **WARNING:** Price pump fluid temperature limits must be observed. Maximum operating temperature is 300°F.
- **CAUTION:** The pump should be thoroughly flushed and drained before disassembly.
- **CAUTION:** For larger pump motor units, weight may exceed 65 lbs. (30 kg).

CAUTION: Maximum working pressure for seals:

- | | |
|------------------|---------------------------|
| ○ Type 6 Seal | 75 PSI (5.2 bar) |
| ○ Type 6A Seal | 75 PSI (5.2 bar) |
| ○ Type 8 Seal | 325 PSI (22.4 bar) |
| ○ Type 9 Seal | 350 PSI (24.1 bar) |
| ○ Type 21 Seal | 150 PSI (10.3 bar) |
| ○ Type 2106 Seal | 150 PSI (10.3 bar) |

CAUTION: Maximum solid size by pump

- | | |
|---------------|------------------------|
| ○ HP75 / MS50 | 0.030" (0.76mm) |
| ○ SP150 | 0.060" (1.50mm) |
| ○ LT25 | 0.120" (3.05mm) |
| ○ F50/75/95 | 0.150" (3.81mm) |
| ○ OH75 | 0.150" (3.81mm) |
| ○ CD100/150 | 0.150" (3.81mm) |
| ○ CL150 | 0.150" (3.81mm) |
| ○ RC200/300 | 0.380" (9.60mm) |
| ○ XJ-JB100 | 0.120" (3.05mm) |
| ○ XJ-JB150 | 0.250" (6.40mm) |
| ○ XJ-JB200 | 0.440" (11.2mm) |
| ○ XL-XT100 | 0.120" (3.05mm) |
| ○ XL-XT150 | 0.250" (6.40mm) |
| ○ XL-XT200 | 0.440" (11.2mm) |

CAUTION: Minimum flow rate by pump

- | | |
|---------------|--------------------------|
| ○ HP75 / MS50 | 0.5 GPM (1.9 LPM) |
| ○ SP150 | 10 GPM (38 LPM) |
| ○ LT25 | 0.5 GPM (1.9 LPM) |
| ○ F50/75/95 | 5.0 GPM (19 LPM) |
| ○ OH75 | 7.0 GPM (26 LPM) |
| ○ CD100 | 12 GPM (45 LPM) |
| ○ CD150 | 25 GPM (94 LPM) |
| ○ CL150 | 40 GPM (150 LPM) |
| ○ RC200 | 10 GPM (38 LPM) |
| ○ RC300 | 50 GPM (189 LPM) |
| ○ XJ-JB150 | 20 GPM (75 LPM) |
| ○ XJ-JB150 | 40 GPM (150 LPM) |
| ○ XJ-JB200 | 90 GPM (340 LPM) |
| ○ XL-XT100 | 10 GPM (38 LPM) |
| ○ XL-XT150 | 35 GPM (132 LPM) |
| ○ XL-XT200 | 50 GPM (189 LPM) |



GENERAL TERMS OF SALE FOR PRODUCTS

1. GENERAL

A. Seller's price is based on these sales terms and conditions. The agreement and inclusion of other or amended terms in this contract will result in a change (including increase) in Seller's price (as may be contained in any price books or quotations) to reflect such other or amended terms. This contract shall represent the final, complete and exclusive statement of the agreement between the parties and may not be modified, supplemented, explained or waived by parole evidence, any Terms and Conditions contained in Buyer's purchase order or request for quotation, any course of dealings between the parties, Seller's performance or delivery, or in any other way. The Terms and Conditions of this contract may only be modified or waived in a written document signed by an Officer of Seller. These terms are intended to cover all activity of Seller and Buyer hereunder, including sales and use of products, parts and work and all related matters (references to products include parts and references to work include construction, installation and start-up). Any reference by Seller to Buyer's specifications and similar requirements are only to describe the products and work covered hereby and no warranties or other terms therein shall have any force of effect. Any information provided by Seller including, but not limited to, suggestions as to specific equipment does not imply any guarantee of specific suitability and/or material compatibility in a particular application, since many factors outside the control of Seller may affect the suitability of products in a particular application. Catalogs, circulars, similar pamphlets and information contained on websites of the Seller are issued for general information purposes only and shall not be deemed to modify the provisions hereof.

B. The agreement formed hereby and the language herein shall be construed and enforced under the Uniform Commercial Code as in effect in the State of California on the date hereof.

2. TAXES

Any sales, use or other similar type taxes imposed on this sale or on this transaction and/or any import or export duties or fees as may be assessed or imposed on or as a result of deliveries under this transaction are not included in the price. Such taxes shall be billed separately to the Buyer. Seller will accept a valid exemption certificate from the Buyer if applicable; however, if an exemption certificate previously accepted is not recognized by the governmental taxing authority involved and the Seller is required to pay the tax covered by such exemption certificate. Buyer agrees to promptly reimburse Seller for the taxes paid.

3. PERFORMANCE, INSPECTION AND ACCEPTANCE

A. Unless Seller specifically assumes installation, construction or start-up responsibility, all products shall be finally inspected and accepted within thirty (30) days after arrival at point of delivery. Where seller has responsibility for installation, construction or start-up all work shall be finally inspected and accepted within thirty (30) days after completion of the applicable work by Seller. All claims whatsoever by Buyer, (including claims for shortages) except only those provided for under the WARRANTY AND LIMITATION OF LIABILITY and PATENTS Clauses, hereof, must be asserted in writing by Buyer within said thirty (30) day period or they are waived. If this contract involves partial performance, all such claims must be asserted within said thirty (30) day period for each partial performance. There shall be no revocation of acceptance. Rejection may be only for defects substantially impairing the value of products or work and Buyer's remedy for lesser defects shall be those provided for under the WARRANTY AND LIMITATION OF LIABILITY Clause.

B. Seller shall not be responsible for non-performance or for delays in performance occasioned by any causes beyond Seller's reasonable control, including, by way of example and not limitation, to labor difficulties, delays of vendors or carriers, fires, governmental actions, or shortages of material, components, labor, or manufacturing facilities. Any delays so occasioned shall affect a corresponding extension of Seller's performance dates, which are, in any event, understood to be approximate. IN NO EVENT SHALL BUYER BE ENTITLED TO INCIDENTAL OR CONSEQUENTIAL DAMAGES FOR LATE PERFORMANCE OR FOR A FAILURE TO PERFORM. Seller reserves the right to make partial shipments and to ship products, parts or work which may be completed prior to the scheduled performance date.

C. In the event that Seller has agreed to mount motors, turbines, gears, or other products which are not manufactured by Seller and which are not an integral part of Seller's manufactured product, and a delay in the delivery of such products to Seller occurs that will cause a delay in Seller's performance date, Seller reserves the right to ship its product upon completion of manufacture and to refund an equitable portion of the amount originally included in the purchase price for mounting without incurring liability for non-performance.

D. Seller reserves to itself the right to change its specifications, drawings and standards if such changes will not impair the performance of its products, and parts, and further those products, and parts, will meet any of Buyer's specifications and other specific product requirements which are a part of this agreement. Seller is a global supplier of products and utilizes parts and products obtained worldwide, and Seller's products supplied under this contract shall be subject to Seller's sole determination as to all manufacturing, sourcing, assembly and supply unless otherwise specifically agreed in writing.

E. The manufacture and inspection of products and parts shall be to Seller's Engineering and Quality Assurance standards, plus such other inspections or tests of documentation as are specifically agreed to by Seller. Requirements for any additional inspection, tests, documentation, or Buyer witness of manufacture, test, and/or inspection shall be subject to additional charges.

4. TITLE AND RISK OF LOSS

Title and risk of loss shall pass to buyer upon delivery of products at the designated "Ex Works" as defined by Incoterms, unless other wise agreed by the parties.

5. EROSION AND CORROSION

It is specifically understood that products and parts sold hereunder are not warranted for operation with erosive or corrosive fluids or for operation with any fluid or under any operating condition in variance with the specifications of this contract. No product or part shall be deemed to be defective by reason of failure to resist erosive or corrosive action of any fluid and Buyer shall have no claim whatsoever against Seller therefore. No product shall be deemed defective by reason of any effect on Seller's products of the action or results (such as vibration) of any goods or system (such as piping) not supplied by Seller.

6. BUYER'S RESPONSIBILITY

The design specifications of the equipment require the operation of the equipment within certain parameters and may call for the use of speed controls, safety devices, set points or other control devices to insure that the operation remains within design parameters. Buyer agrees and understands that the equipment must be operated and maintained within design specifications and operated within the specifications of the contract, irrespective of whether controls or devices are otherwise required.

7. WARRANTY AND LIMITATION OF LIABILITY.

A. Seller warrants only that its product and parts, when shipped, will be free from defects in materials and workmanship. All claims for defective products or parts under this warranty must be made in writing immediately upon discovery and, in any event, within two (2) years of shipment by seller and all claims for defective work must be made in writing immediately upon discovery. Defective items must be held for Seller's inspection and returned to the sellers' point of original shipment upon request.

ANY UNAUTHORIZED DISSASSEMBLY, ALTERATION OF OR TAMPERING WITH ANY PRODUCT OR COMPONENT MAY "VOID" THE WARRANTY, IN THAT SUCH ACTION WILL RESULT IN SELLER BEING RELEASED AND RELIEVED FROM ITS OBLIGATIONS UNDER THIS WARRANTY AND FOR ANY FURTHER COSTS OR ACTIONS UNDER CLAUSE 7.C, FOLLOWING, AND THE BUYER ASSUMING SOLE RESPONSIBILITY FOR THE COSTS AND RESULTS OF SUCH ACTION. THE FOREGOING IS EXPRESSLY IN LIEU OF ALL OTHER WARRANTIES WHATSOEVER, EXPRESS, IMPLIED AND STATUTORY, INCLUDING WITHOUT LIMITATION, THE IMPLIED, WARRANTIES OF MERCHANTABILITY AND FITNESS.

B. ANY PRODUCT(S) SOLD HEREUNDER WHICH ARE NOT MANUFACTURED BY SELLER ARE NOT WARRANTED BY SELLER and shall be covered only by the express warranty, if any, of the manufacturer thereof. With respect to products and parts not manufactured by Seller, Seller's only obligation shall be to assign to Buyer, to the extent possible, whatever warranty Seller obtains from the manufacturer.

C. Upon Buyer's submission of a claim as provided above and its substantiation, Seller shall at its option either (i) repair or replace its product, part or work at the original place of shipment, or (ii) refund an equitable portion of the purchase price.

D. THE FOREGOING IS SELLER'S ONLY OBLIGATION AND BUYER'S EXCLUSIVE REMEDY FOR BREACH OF WARRANTY AND, EXCEPT FOR THE REMEDIES PERMITTED UNDER THE PERFORMANCE, INSPECTION AND ACCEPTANCE AND THE PATENTS CLAUSES HEREOF, THE FOREGOING IS BUYER EXCLUSIVE REMEDY AGAINST SELLER FOR ALL CLAIMS ARISING HEREUNDER OR RELATING HERETO WHETHER SUCH CLAIMS ARE BASED ON BREACH OF CONTRACT, TORT (INCLUDING NEGLIGENCE OR STRICT LIABILITY), INDEMNITY OR OTHER THEORIES. BUYER'S FAILURE TO SUBMIT A CLAIM AS PROVIDED ABOVE SHALL SPECIFICALLY WAIVE ALL CLAIMS FOR DAMAGES OR OTHER RELIEF, INCLUDING BUT NOT LIMITED TO CLAIMS BASED ON LATENT DEFECTS. IN NO EVENT SHALL BUYER BE ENTITLED TO INDIRECT, SPECIAL, INCIDENTAL OR CONSEQUENTIAL DAMAGES, NOR FOR DAMAGES FOR LOSS OF USE, MOST PROFITS OR REVENUE, INTEREST, LOST GOODWILL, WORK OR PRODUCTION STOPPAGE, IMPAIRMENT OF OTHER GOODS, INCREASED EXPENSES OF OPERATION, OR THE COST OF PURCHASING REPLACEMENT POWER OR OTHER SERVICES BECAUSE OF SERVICE INTERRUPTIONS. FURTHERMORE, IN NO EVENT SHALL SELLER'S TOTAL LIABILITY FOR DAMAGES OF BUYER EXCEED THE PURCHASE PRICE OF THE PRODUCTS OR PARTS MANUFACTURED BY SELLER AND UPON WHICH SUCH LIABILITY IS BASED. ANY ACTION ARISING HEREUNDER RELATED HERETO, WHETHER BASED ON BREACH OF CONTRACT, TORT (INCLUDING NEGLIGENCE) OR OTHER THEORIES, MUST BE COMMENCED WITHIN ONE (1) YEAR AFTER THE CAUSE OF ACTION ACCRUES OR IT SHALL BE BARRED.

8. PURCHASER'S REPRESENTATIONS & WARRANTIES

Purchaser represents and warrants that the products(s) covered by this contract shall not be used in or in connection with a nuclear facility or application. The parties agree that this representation and warranty is material and is being relied on by seller. This provision may be modified in a separate writing signed by an officer of Price Pump Co.

9. PATENTS

Seller agrees to assume the defense of any suit for infringement of any patents brought against Buyer to the extent of such suit charges infringement of an apparatus or product claim by Seller's product in and of itself, provided (i) said product is built entirely to Seller's design, (ii) Buyer notifies Seller in writing of the filing of such suit within ten (10) days after the service of process thereof, and (iii) Seller is given complete control of the defense of such suit, including the right to defend, settle and make changes in the product for the purpose of avoiding infringement of any process or method claims. Provided however, Seller will not defend any suit for infringement of a claimed patent where such alleged infringement is the result of following specific instruction furnished by Seller.

10. EXTENT OF SUPPLY

Only products as listed in Seller's proposal are included in this agreement. It must not be assumed that Seller has included anything beyond same.

11. MANUFACTURING SOURCES

To maintain delivery schedules, Seller reserves the right to have all or any part of the Buyer's order manufactured at any of Sellers', sellers' licensees or sub contractors' plants, globally.

12. TERMS OF PAYMENT

Net 30 days from date of invoice.

13. ARBITRATION

In the event a dispute arises between the parties relating to or arising out of this agreement, the parties agree to attempt to have their senior management amicably settle the matter. In the event that the matter cannot be settled, the parties shall submit all disputes relating to this Agreement (whether contract, tort, products liability or otherwise) to binding Arbitration before a panel of arbitrators under the Commercial Dispute Resolution Procedures of the American Arbitration Association. Each party shall appoint an arbitrator and the third shall be selected in accordance with the rules of the American Arbitration Association. Judgment upon the award may be entered in any court having jurisdiction. The parties shall cooperate in providing reasonable disclosure of relevant documents. Each party shall bear its own